



Ball and Plug Valves

Catalog 4121-BV

July 2014

- aerospace
- climate control
- electromechanical
- filtration
- fluid & gas handling
- hydraulics
- pneumatics
- process control
- sealing & shielding



ENGINEERING YOUR SUCCESS.



Description.....	Page
B Series Ball Valves, 6,000 psi Maximum*	2
Two-Way	2
Three-Way	4
PR Series Rotary Plug Valves, 3,000 psi Maximum*	12
MB Series Ball Valves, 3,000 psi Maximum*	16
Two-Way In-Line	17
Two-Way Angle	18
Three-Way	18
Four-Way	20
Five-Way	20
HB Series Ball Valves, 10,000 psi Maximum*	22
MPB Series Ball Valves, 20,000 psi Maximum*	28
Two-Way	28
Three-Way	29
SWB Series Ball Valves, 2,500 psi Maximum*	32
Pneumatic Actuators	38
61 Model	39
62, 63, 64, 65, 66, 68, and 69 Models	39
90° Models (AC, AO and AD)	41
180° Models (ACX and ADX).....	42
Electric Actuators	44
70 Series	45
80 Series	46
90 Series	47
B12 Series Ball Valves, 4,000 psi Maximum*	52
Available End Connections	54
Offer of Sale	55

B
PR
MB
HB
MPB
SWB
Pneu Act
Elec Act
B12
End Conn

* Actual pressure rating will be determined by the valve configuration, such as body material, seat material, etc. Contact the factory for more information.

⚠ WARNING – USER RESPONSIBILITY

FAILURE OR IMPROPER SELECTION OR IMPROPER USE OF THE PRODUCTS DESCRIBED HEREIN OR RELATED ITEMS CAN CAUSE DEATH, PERSONAL INJURY AND PROPERTY DAMAGE.

This document and other information from Parker-Hannifin Corporation, its subsidiaries and authorized distributors provide product or system options for further investigation by users having technical expertise.

The user, through its own analysis and testing, is solely responsible for making the final selection of the system and components and assuring that all performance, endurance, maintenance, safety and warning requirements of the application are met. The user must analyze all aspects of the application, follow applicable industry standards, and follow the information concerning the product in the current product catalog and in any other materials provided from Parker or its subsidiaries or authorized distributors.

To the extent that Parker or its subsidiaries or authorized distributors provide component or system options based upon data or specifications provided by the user, the user is responsible for determining that such data and specifications are suitable and sufficient for all applications and reasonably foreseeable uses of the components or systems.

Offer of Sale

The items described in this document are hereby offered for sale by Parker-Hannifin Corporation, its subsidiaries or its authorized distributors. This offer and its acceptance are governed by the provisions stated in the detailed "Offer of Sale" elsewhere in this document or available at www.parker.com/ipdus.

© Copyright 2014 Parker Hannifin Corporation. All Rights Reserved.



B

Introduction

Parker manually, pneumatically, and electrically actuated two-way B Series Ball Valves provide quick 1/4 turn on-off control of fluids utilized in process and instrumentation applications. A broad selection of valve body, seat, and seal materials provide a wide range of pressures and temperatures at which the valve may be used.

Features

- ▶ Free floating ball design provides seat wear compensation.
- ▶ Available in 316 stainless steel and brass construction. Monel® Alloy 400 and Hastelloy® C-276 construction available upon request.
- ▶ Micro-finished ball provides a positive seal.
- ▶ Straight through flow path for minimum pressure drop.
- ▶ Bi-directional flow.
- ▶ Wide variety of US Customary and SI ports.
- ▶ 90° actuation.
- ▶ Panel mountable.
- ▶ Adjustable PTFE stem seal can be maintained in-line.
- ▶ Handle indicates flow direction.
- ▶ Low operating torques.
- ▶ Positive handle stops.
- ▶ Color coded handles.
- ▶ Optional pneumatic and electric actuation.
- ▶ Optional live-loaded PTFE stem seals.
- ▶ Optional non-adjustable O-ring stem seals.
- ▶ Optional upstream and downstream drain models.
- ▶ Optional stainless steel and extended handles.

Specifications

Pressure Ratings:

Material	CWP	with PTFE Seats
316 Stainless Steel	6000 psig (414 bar)*	1500 psig (103 bar)
Brass	3000 psig (207 bar)	1500 psig (103 bar)
Monel® Alloy 400		
B2 and B6:	3000 psig (207 bar)	1500 psig (103 bar)
B8:	2000 psig (138 bar)	1500 psig (103 bar)
Hastelloy® C-276		
B2 and B6:	4000 psig (276 bar)	1500 psig (103 bar)
B8:	3000 psig (207 bar)	1500 psig (103 bar)

* B6 Series: 6000 psig rating or 4400 psig (303 bar) CWP
B8 Series: 6000 psig rating or 4000 psig (276 bar) CWP

Pressure Rating and Tubing Selection

For working pressures of A-LOK® and CPI™ tube connections, please see the Instrument Tubing Selection Guide (Bulletin 4200-TS), found in the Technical Section of the Parker Instrumentation Process Control Binder, or the Parker Instrument Fitting Installation Manual (Bulletin 4200-B4).

For working pressures of valves with external or internal pipe threads, please see Catalog 4260, Instrumentation Pipe Fittings.

Materials of Construction

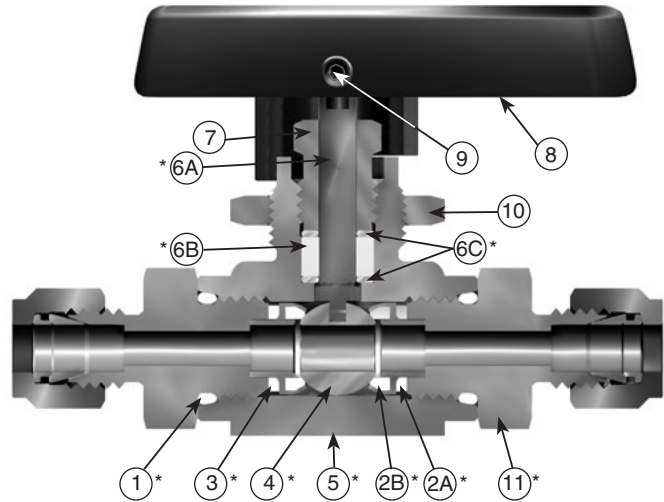

Model Shown: 6A-B6LJ-SSP

Materials of Construction

Item #	Part Description	Stainless Steel	Brass
*1	Connector O-Ring	PTFE**	
*2A	Seat Retainer	ASTM A 276 Type 316	ASTM B 16 Alloy C36000
*2B	Seat	PTFE, PCTFE, PEEK	
*3	Retainer Seal	PTFE**	
*4	Ball	316 Stainless Steel	
*5	Body	ASTM A 351 Grade CF3M	ASTM B 283 Alloy C37700
*6A	Stem	ASTM A 276 Type 316	
*6B	Stem Seal	PTFE**	
*6C	Stem Washer	316 Stainless Steel	
7	Packing Nut	ASTM A 479 Type 316	ASTM B 453 Alloy C34000
8	Handle	Nylon 6/6	
9	Handle Set Screw	Stainless Steel	
10	Panel Nut	316 Stainless Steel	
*11	End Connector	ASTM A 479 Type 316	ASTM B 16 Alloy C36000

* Wetted Parts.

** Optional stem seal and body seal materials are described in the How to Order section.

Lubrication: Perfluorinated Polyether.

Hastelloy® is a registered trademark of Haynes International.
Monel® Alloy 400 is a registered trademark of Special Metals Corporation.

Dimensions & Flow Data

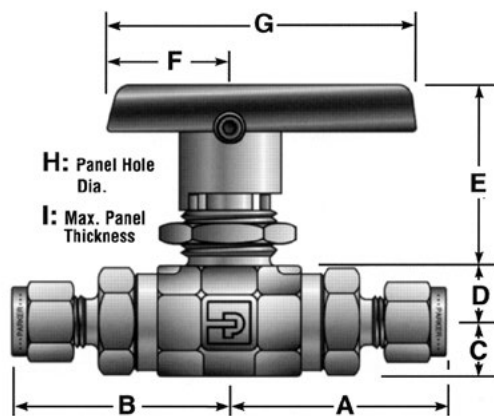

Model Shown:
4A-B6LJ-SSP

Port Size	Basic Part #	Flow Data				End Connections		Dimensions Inches (mm)								
		Orifice		Cv	X _T [*]	Port 1	Port 2	A†	B†	C	D	E	F	G	H	I
		Inch	mm													
1A	B2L	0.052	1.3	0.06	0.45	1/16" A-LOK®	1.30	1.30	0.33 (8.4)	0.33 (8.4)	0.94 (23.9)	0.75 (19.1)	1.88 (47.8)	0.58 (14.7)	0.13 (3.3)	
1Z						1/16" CPI™	(33.0)	(33.0)								
2A		0.093	2.4	0.21	0.47	1/8" A-LOK®	1.36	1.36								
2Z						1/8" CPI™	(34.5)	(34.5)								
2F		0.165	4.2	0.93	0.43	1/8" Female NPT	1.07	1.07								
2M		0.165	4.2	0.93	0.43	1/8" Male NPT	1.18	1.18								
4A		0.165	4.2	0.93	0.43	1/4" A-LOK®	1.48	1.48								
4Z						1/4" CPI™	(37.6)	(37.6)								
4M		0.165	4.2	0.93	0.43	1/4" Male NPT	1.35	1.35								
M3A		0.086	2.2	0.18	0.44	3mm A-LOK®	1.37	1.37								
M3Z						3mm CPI™	(34.8)	(34.8)								
4A		0.187	4.7	1.04	0.42	1/4" A-LOK®	1.74	1.74								
4Z	1/4" CPI™					(44.2)	(44.2)									
4F	0.250	6.4	2.34	0.29	1/4" Female NPT	1.51	1.51									
4M	0.250	6.4	2.34	0.29	1/4" Male NPT	1.62	1.62									
4Q	0.180	4.6	1.03	0.42	1/4" UltraSeal	1.51	1.51									
4V	0.188	4.8	1.04	0.42	1/4" VacuSeal	1.75	1.75									
6A	B6L	0.250	6.4	2.34	0.29	3/8" A-LOK®	1.80	1.80	0.42 (10.7)	0.47 (11.9)	1.53 (38.9)	1.00 (25.4)	2.50 (63.5)	0.77 (19.6)	0.25 (6.4)	
6Z						3/8" CPI™	(45.7)	(45.7)								
6M		0.250	6.4	2.34	0.29	3/8" Male NPT	1.62	1.62								
6Q		0.250	6.4	2.34	0.29	3/8" UltraSeal	1.51	1.51								
M6A		0.187	4.7	1.04	0.42	6mm A-LOK®	1.75	1.75								
M6Z						6mm CPI™	(44.5)	(44.5)								
M8A		0.250	6.4	2.34	0.42	8mm A-LOK®	1.78	1.78								
M8Z						8mm CPI™	(45.2)	(45.2)								
M10A		0.250	6.4	2.34	0.42	10mm A-LOK®	1.81	1.81								
M10Z						10mm CPI™	(46.0)	(46.0)								
6F		0.406	10.3	6.42	0.37	3/8" Female NPT	1.95	1.95								
8F		0.406	10.3	6.42	0.37	1/2" Female NPT	2.15	2.15								
8A	0.406	10.3	6.42	0.37	1/2" A-LOK®	2.34	2.34									
8Z					1/2" CPI™	(59.4)	(59.4)									
8M	0.406	10.3	6.42	0.37	1/2" Male NPT	2.22	2.22									
8Q	0.375	9.5	5.57	0.37	1/2" UltraSeal	1.92	1.92									
8V	0.406	10.3	6.42	0.37	1/2" VacuSeal	2.21	2.21									
12A	0.406	10.3	6.42	0.37	3/4" A-LOK®	2.33	2.33									
12Z					3/4" CPI™	(59.2)	(59.2)									
12F	0.406	10.3	6.42	0.37	3/4" Female NPT	2.25	2.25									
M12A	0.375	9.5	5.57	0.37	12mm A-LOK®	2.33	2.33									
M12Z					12mm CPI™	(59.2)	(59.2)									
M16A	0.406	10.3	6.42	0.37	16mm A-LOK®	2.33	2.33									
M16Z					16mm CPI™	(59.2)	(59.2)									

* Tested in accordance with ISA S75.02. Gas flow will be choked when $P_1 - P_2 / P_1 = X_T$.
 † For CPI™ and A-LOK®, dimensions are measured with nuts in the finger tight position

Dimensions in inches/millimeters are for reference only, subject to change.

B

Introduction

Parker manually, pneumatically, and electrically actuated three-way B Series Ball Valves may be used as diverting or selecting valves for fluids utilized in process and instrumentation applications. The standard three-way diverter valve is designed to accept media through the bottom port and direct it out of two outlet ports. When equipped with spring-loaded seats, the three-way valve may be used as a selector valve, alternately accepting media from either of two inlet sources (side ports) and directing it through a single outlet (bottom port).

Features

- ▶ Available in 316 stainless steel and brass construction. Monel® Alloy 400 and Hastelloy® C-276 construction available for Diverter Valves upon request.
- ▶ Micro-finished ball provides a positive seal.
- ▶ Wide variety of US Customary and SI ports.
- ▶ 180 degree actuation.
- ▶ Panel mountable.
- ▶ Adjustable PTFE stem seal can be maintained in-line.
- ▶ Handle indicates flow direction.
- ▶ Low operating torques.
- ▶ Positive handle stops.
- ▶ Color coded handles.
- ▶ Optional pneumatic and electric actuation.
- ▶ Optional live-loaded PTFE stem seals.
- ▶ Optional non-adjustable O-ring stem seals.
- ▶ Optional stainless steel and extended handles.

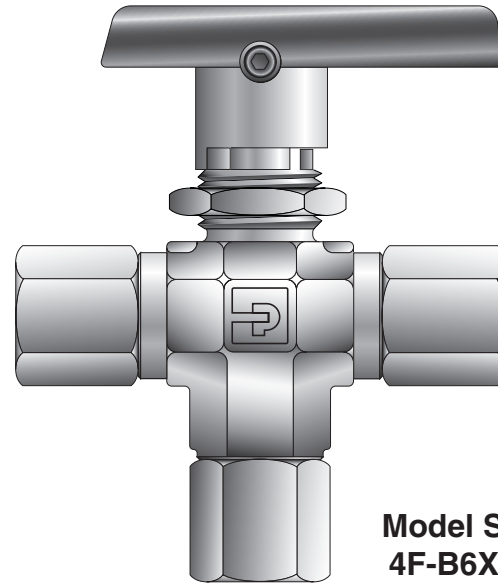

**Model Shown:
4F-B6XJ2-BP**

Diverter Valve Specifications

Pressure Ratings with bottom port as inlet:

Material	CWP	with PTFE Seats
316 Stainless Steel	6000 psig (414 bar)*	1500 psig (103 bar)
Brass	3000 psig (207 bar)	1500 psig (103 bar)
Monel® Alloy 400		
B2 and B6:	3000 psig (207 bar)	1500 psig (103 bar)
B8:	2000 psig (138 bar)	1500 psig (103 bar)
Hastelloy® C-276		
B2 and B6:	4000 psig (276 bar)	1500 psig (103 bar)
B8:	3000 psig (207 bar)	1500 psig (103 bar)

* B6 Series: 6000 psig rating or 4400 psig (303 bar) CWP
B8 Series: 6000 psig rating or 4000 psig (276 bar) CWP

Pressure Rating and Tubing Selection

For working pressures of A-LOK® and CPI™ tube connections,

Pressure Rating with side ports as inlet:

150 psig (10 bar)

Selector Valve Specifications

(Spring Loaded – B6 and B8 models only)

Pressure Rating with bottom port as inlet:

316 Stainless Steel..... 6000 psig (414 bar) CWP*
Brass3000 psig (207 bar) CWP

Pressure Rating with side ports as inlet:

316 Stainless Steel and Brass.....3000 psig (207 bar) CWP

Pressure Rating and Tubing Selection

For working pressures of A-LOK® and CPI™ tube connections, please see the Instrument Tubing Selection Guide (Bulletin 4200-TS), found in the Technical Section of the Parker Instrumentation Process Control Binder, or the Parker Instrument Fitting Installation Manual (Bulletin 4200-B4).

For working pressures of valves with external or internal pipe threads, please see Catalog 4260, Instrumentation Pipe Fittings.

Diverter Valve

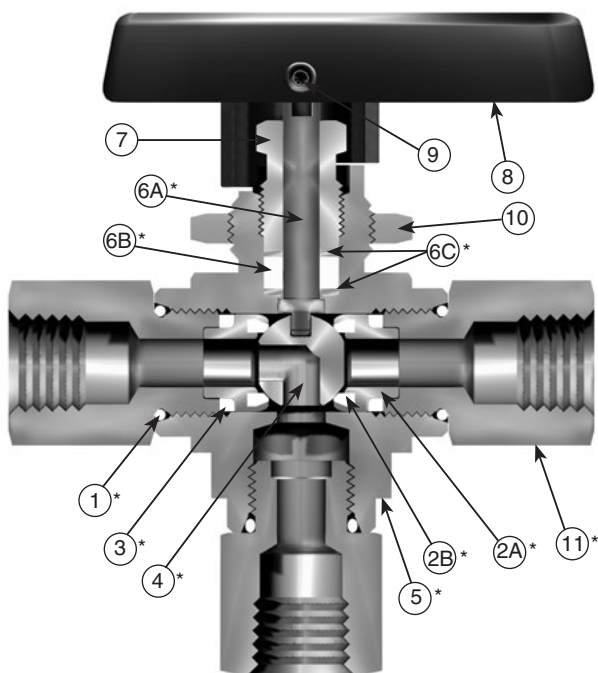

Model Shown: 4F-B6XJ-SSP

Selector Valve

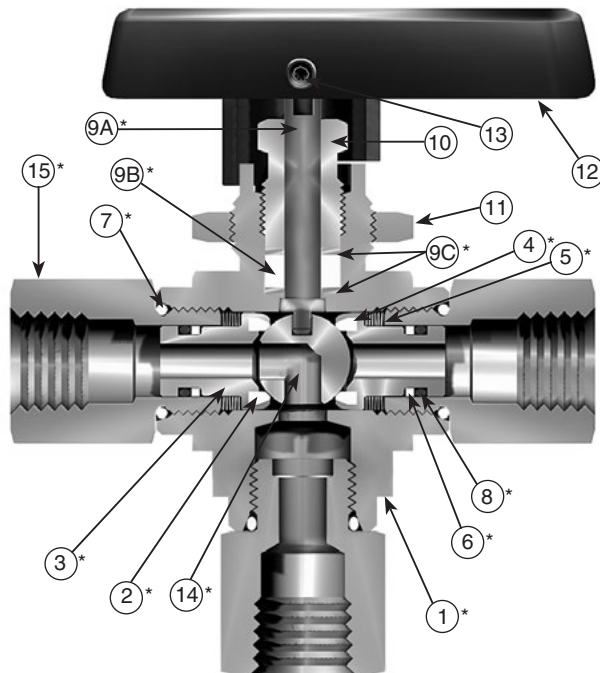

Model Shown: 4F-B6XS2-SSP

Materials of Construction

Item #	Part Description	Stainless Steel	Brass
*1	Connector O-Ring	PTFE**	
*2A	Seat Retainer	ASTM A 276 Type 316	ASTM B 16 Alloy C36000
*2B	Seat	PTFE, PCTFE, PEEK	
*3	Retainer Seal	PTFE**	
*4	Ball	316 Stainless Steel	
*5	Body	ASTM A 351 Grade CF3M	ASTM B 283 Alloy C37700
*6A	Stem	ASTM A 276 Type 316	
*6B	Stem Seal	PTFE**	
*6C	Stem Washer	316 Stainless Steel	
7	Packing Nut	ASTM A 479 Type 316	ASTM B 453 Alloy C34000
8	Handle	Nylon 6/6	
9	Handle Set Screw	Stainless Steel	
10	Panel Nut	316 Stainless Steel	
*11	End Connector	ASTM A 479 Type 316	ASTM B 16 Alloy C36000

* Wetted Parts.

** Optional stem seal and body seal materials are described in the How to Order section.

Lubrication: Perfluorinated Polyether.

Materials of Construction

Item #	Part Description	Stainless Steel	Brass
1	Body	ASTM A 351 Grade CF3M	ASTM B 283 Alloy C37700
*2	Seat	PTFE, PEEK	
*3	Seat Retainer	ASTM A 276 Type 316	
4	Spring	Stainless Steel	
*5	Seat Retainer Washer	316 Stainless Steel	
*6	Back-up Ring	PTFE	
*7	Connector O-Ring	PTFE**	
*8	Seat Retainer O-Ring	Fluorocarbon Rubber**	
*9A	Stem	ASTM A 276 Type 316	
9B	Stem Seal	PTFE	
*9C	Stem Washer	316 Stainless Steel***	
10	Packing Nut	ASTM A 479 Type 316	ASTM B 453 Alloy C34000
11	Panel Nut	316 Stainless Steel	
12	Handle	Nylon 6/6	
13	Handle Set Screw	Stainless Steel	
*14	Ball	316 Stainless Steel	
*15	End Connector	ASTM A 479 Type 316	ASTM B 16 Alloy C36000

* Wetted Parts.

** Optional stem seal and body seal materials are described in the How to Order section.

Lubrication: Perfluorinated Polyether.

***The lower stem washer material is PEEK for B8 Selector Valves.
Lubrication: Perfluorinated polyether.

How to Order

The correct part number is easily derived from the following example and ordering chart. The four product characteristics required are coded as shown in the chart.

The example below describes a SWB8L Two-Way Ball Valve with 1/2" A-LOK® end connections for ports 1 and 2, reinforced PTFE seats, Nitrile rubber body seals, and stainless steel construction.

* **Note:** If ports 1 and 2 are the same, eliminate the port 2 designator.

Example:

8A			SWB8L		RT	BN	SS
Port Size	Port 1*	Port 2*	Valve Series	Valve Configuration	Seat Material	Seal Material	Body Material
4	Z	CPI™ Tube	SWB4	L 2-Way	PKR Virgin PEEK ¹	T PTFE	SS Stainless Steel
6	A	A-LOK® Tube	SWB8		RT Glass Reinforced PTFE	BN Nitrile Rubber	
8	F	Female NPT	SWB12			EPR Ethylene Propylene Rubber	
12	W	Tube Socket Weld	SWB16			V Fluorocarbon Rubber	
16	PSW	Pipe Socket Weld				G Grafoil® Gasket ^{1,2}	
	PBW8	Pipe Butt weld (Schedule 80)					

1 Not available in size 12.

2 Grafoil® Seals only available with PEEK Seats.

Note: Upper and Lower PTFE packing is replaced with PEEK when valves are ordered with PEEK Seats.

How to Order Options

Examples

Lever Lock-Out Devices –

Add the suffix -LD to the end of the part number to order directly on the valve.
For field installation, order part number as shown in the example.

4F-SWB8L-RT-V-SS-LD
SWB8/12-HANDLE-LOCKING

Oval Handles – Add the suffix -S to the end of the part number.

8A-SWB8L-RT-T-SS-S

Oval Handle Lock-Out Devices –

Add the suffix -LD to the end of the part number to order directly on the valve.
For field installation, order part number as shown in the example.

6F-SWB8L-RT-V-SS-S-LD
SWB8/12-HANDLE-OVAL-LOCKING

Pneumatic Actuators – For detailed actuator information, refer to the [Pneumatic Actuators section](#) of this catalog.

For factory assembly, add the actuator part number as the suffix to the valve part number.

For field installation, specify the the actuator desired.

The appropriate mounting hardware may be obtained by adding the valve series and actuator size to the prefix MK-.

8F-SWB8L-RT-BN-SS-61AC-2
61AC-2

MK-SWB8L-61

Electric Actuators – For detailed actuator information, refer to the [Electric Actuators section](#) of this catalog.

For factory assembly, add the actuator part number as the suffix to the valve part number.

For field installation, specify the actuator desired.

The appropriate mounting hardware may be obtained by adding the valve series and actuator series to the prefix MK-.

8A-SWB8L-RT-EPR-SS-71A
71A

MK-SWB8L-70.

Grafoil® is a registered trademark of UCAR Carbon Technology Corporation